

GatorCam4USB Controller

- 1 **On/Off Switch.**
- 2 **Keypad and function keys:** Allows the operator to select functions and edit text entries.
- 3 **Keyboard:** Provides enhanced text entry capabilities and short-cuts to access system functions.
- 4 **Display:** LCD screen shows image and various on-screen information such as deployed rod length, operator generated titles, time and date.
- 5 **Link Cable Socket (at rear of unit):** Connector for the link cable.
- 6 **Fuse Holder:** 5mm x 20mm T3.15A 250V cartridge fuse.
- 7 **RCA Video Jacks:** Allows an external composite video source to be displayed by the GatorCam4USB controller or recorded onto Compact Flash. GatorCam4USB video can also be displayed or recorded on an external device.
- 8 **Power Socket:** DC power input from vehicle supply, battery box or mains adapter.
- 9 **Compact Flash slot:** Compact Flash for video recording and later playback on the controller or PC. Also used for software upgrades and storing diagnostic log files.
- 10 **Keyboard Socket:** Keyboard connector.
- 11 **Audio Socket:** Connection for headset using standard 3.5mm connector.
- 12 **PC socket:** Type B USB connection allows file transfers.
- 13 **USB socket:** Type A USB connection for USB flash drives. Memory Sticks can be used video recording and later playback on the controller or PC. Also used for software upgrades and storing diagnostic log files.

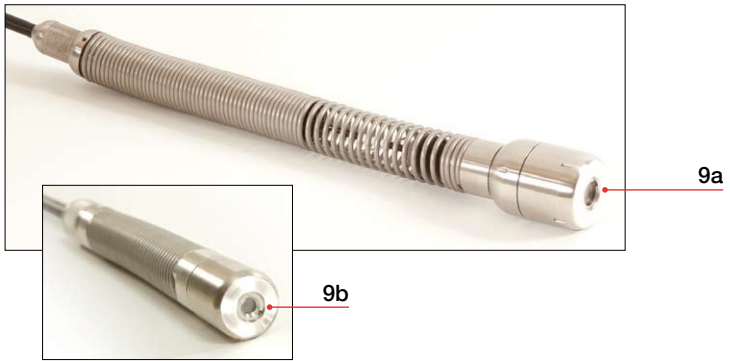
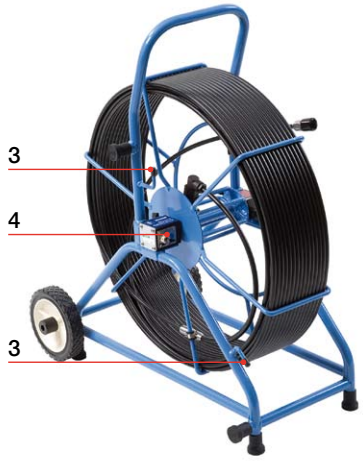
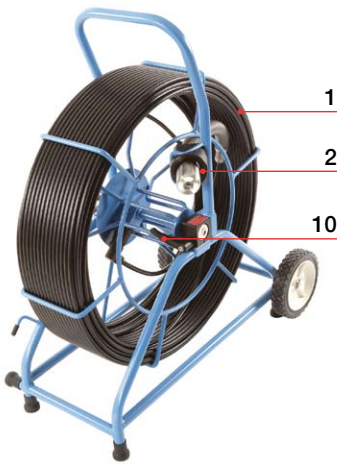

Camera/Pushrod reel

- 1 **Pushrod Reel:** Holds the pushrod on a revolving drum. The pushrod is up to 150m (500ft) in length.
- 2 **Rod Guide:** Guides the rod on and off the reel.
- 3 **Stowage Hooks:** To store the link cable on the cable reel.
- 4 **Cable Socket:** Connector for the link cable.
- 5 **Link Cable:** To connect the cable reel to the controller
- 6 **Skids:** Protect the camera during use and centers the camera in the pipe. Refer to the operation manual for skid and brush installation.
- 7 **Universal Flexi:** Attaches to the end of the cable rod to allow the camera to negotiate small radius bends.
- 8 **Sonde (8a), flexisondes (8b) and not detachable Plumbers sonde (8c) (GatorCam4 Plumbers reel only):** transmit a signal to allow the position of the camera to be pinpointed using an RD7000™DL+ receiver (optional purchase).
- 9 **Camera:** Two color camera options are available:
 - a. 50mm (2") diameter camera with manually adjustable focus for up to 230mm (9") diameter pipes.
 - b. 25mm (1") diameter camera with manually adjustable focus for up to 100mm (4") diameter pipes.
- 10 **Brake:** Can be adjusted to control the reel movement or to lock the reel.
Mains adapter (not shown): Connects the controller to mains power.
Vehicle power lead (not shown): Connects the controller to your vehicle power socket (12-24V).
Battery pack (not shown): Optional battery pack to allow the use of the system where mains power is not available.
Controller Clamp (not shown): Allows the controller to be mounted onto the cable reel (controller clamp optional on the Plumbers and Mini models).

Environmental specifications

- **Storage Temperature:** -4 to 176F / -20 to 80C
- **Operating Temperature:** 14 to 122F / -10 to 50C
- **IP Rating:**
 - Controller: IP55 (covers closed)
IP53 (covers open and socket panel closed)
 - Mains adapter: IP67 rated for outdoor use
 - Cameras: IP68 to 330' (100m) / 11bar

Quick start procedure

- Install the controller on top of the camera reel if desired (optional on the Plumbers and Mini models).
- Connect the link cable to the connectors on the rear of the controller and on the pushrod reel.
- Ensure a compatible removable storage device, FAT32 formatted, is loaded into the controller (Compact Flash or USB Flash Drive).
- Connect the power supply to the controller.
- Switch the controller on.
- Press OK to clear the splash screen.
- Calibrate and zero the camera's position. Press F10 on the keyboard or Δ and ∇ on the keypad simultaneously.
- Deploy the camera into the pipe as required.
- If required zero the camera's position by pressing F10 on the keyboard or press Δ and ∇ on the keypad simultaneously.
- On the keypad, press the \bigcirc key to record the inspection.

Enter job details if required:

- Review Client Name, Site Address and Survey Start and Finish Survey references by pressing the Δ and ∇ keys. Press OK to Edit and press OK, again, to accept the changes.
- On the keypad, press the \bigcirc key again to start recording the inspection.
- Press the \square key to take screen captures (if required review Client Name, Site Address and Survey Start and Finish references as described for video recording).
- Press the \square key then press F1 to annotate your video.
- Press OK or enter to make an observation.
- To pause a recording, press \square .
- To stop a recording, press \square .

NOTE: Do not extract the removable storage device during recording or playback. Doing so may corrupt all data on the storage device and crash the controller.

Setup

Cable reel

Connect the link cable to the cable reel socket and to the controller socket and ensure that the connectors have been tightened.

Power lead

⚠ WARNING! The controller is not earthed. If any mains operated equipment is connected to the system, the external equipment MUST BE earthed in accordance with the manufacturer's instructions. Failure to earth the attached equipment may result in potentially lethal electric shock.

Release the side catches and open the two halves of the cover.

Open the connection panel cover:

- 1 If required, connect the keyboard to the keyboard socket.
- 2 Connect the power supply (12 to 24V DC vehicle supply, mains adaptor or optional battery pack) to the power socket.
- 3 Insert a suitable Compact Flash Card or USB Flash Drive formatted as FAT32.

Recommended Camera Focus Settings

You should focus your camera to match the internal diameter of the pipe you are about to inspect.

With reference to Tables 1 and 2 place your camera at the required distance from a target object to get optimal image quality.

Use the focus tool provided with your camera to turn the focusing ring until the target object is in focus.

Table 1

1" (25mm) Camera			
Internal Pipe Diameter		Target Object	
Inches	mm	Inches	mm
1.25	32	3.0	76
1.5	38	3.6	92
2	51	4.8	122
3	76	7.2	183
4	102	9.6	244

Table 2

2" (50mm) Camera			
Internal Pipe Diameter		Target Object	
Inches	mm	Inches	mm
2	51	5.6	142
3	76	8.4	213
4	102	11.2	284
6	152	16.8	427
8	203	22.4	569
9	229	25.2	640

Configuration

Once the system is correctly assembled and connected to a power source, you may need to configure the controller's software.

Switch the On/Off switch to On.

After about 5 seconds the Radiodetection splash screen will be displayed for about 5 seconds.

This will be followed by the welcome screen:

- Check that the date and time are correct and that the correct video standard for your country (PAL or NTSC) is displayed.
- Check that the correct reel size is set.
- If a USB Flash Drive or CF card is present, check that the correct memory parameters are displayed (if both a USB drive and CF card are present then only the USB drive parameters will be displayed).

Press OK or Enter to continue.

If required you can set up the correct reel type, date, time and language as follows:

To navigate through the system software use the keypad or keyboard function and arrows keys. Use the ◀ key to return to the previous menu. Use the ▲ and ▼ keys to scroll through the various options and press OK to accept the selection.

Select the correct reel

Select "Menu" (F1 key) to go to the main menu screen, select "Set-up" and press OK.

Select "Reel", press OK to continue to the Reel Setup Menu.

Use the ▲ or ▼ keys to select the correct reel length and type, press OK to confirm your choice.

Press ◀ to exit the Reel Setup Menu.

Basic Controller Set-up

From the main Setup Menu, select "Controller" and press OK .

Select "Basic Settings" and press OK

Select the setting you wish to edit and press OK or Enter.

Use the keyboard to modify Time or Date and use the ▲ and ▼ keys to scroll through the various options.

Press OK to accept the new settings.

When all the required settings have been setup, press F6 to exit to the top-level screen.

TFT Screen Settings

The screen brightness and contrast functions are available on the top level screen.

Press BRI (F5) to set the Screen Brightness or CONTR (F6) to set the Screen Contrast.

Use the ◀ and ▶ keys to set the desired value and press OK to accept your settings.

Jobs

By entering information about your current session Client, Site and Survey the **GatorCam4** USB Controller will organize all your recordings (videos or photos) and observations in Jobs structures. This information will also be used to generate the final detailed report (if required) by using flexisight manager. Consult the operational manual for more details.

To start a new job:

Go to the Job browser: from the main Setup Menu, select “Jobs” and press OK.

Press NEW (F1) and enter Client, Site and Survey details. Press START to start the new job.

To resume or review an existing job:

Go to the Job browser: from the main Setup Menu, select “Jobs” and press OK.

Use the Δ or ∇ keys to select the Job you wish to resume or review and press OK.

Press START (F1) to resume the job,

or:

use the Δ and ∇ keys to select Job details or media (photos or videos), press OK to review, edit or preview.

Recordings

NOTE: Do not remove or install the removable storage device when the system is powered and do not switch off the unit while recording. Failure to comply may damage the removable storage device and /or recordings.

Formatting the removable storage device will delete all the files.

If you are using a USB flash drive device this will automatically be used to store all your data (videos, photos and observations) even in the presence of a compatible CF card.

Video recording

Press the \bigcirc key to start recording.

Enter job details if required:

- Review Client Name, Site Address and Survey Start and Finish Survey references by pressing the Δ and ∇ keys. Press OK to Edit and then press OK again to accept the changes.
- On the keypad, press the \bigcirc key again to start recording the inspection.

Press the \square key to pause a recording, press the \bigcirc key or \square to resume recording.

Press the \square key to finish recording.

Press Fn and \curvearrowright or \curvearrowleft to pan a zoomed video image.

Press \ominus or \oplus to zoom in or out.



Press the rotate keys \curvearrowright or \curvearrowleft to rotate the video image.

To restore an altered image, simultaneously press both video effects keys for example \curvearrowright and \curvearrowleft .

Still pictures

Press the  key at anytime to take still pictures.



Enter job details if required:

- Review Client Name, Site Address and Survey Start and Finish Survey references by pressing the  and  keys. Press OK to Edit and then press OK again to accept the changes.
- On the keypad, press the  key to capture a picture of the screen in jpeg format.



You can take screen captures in recording, playback and general inspection modes. Note that screen captures will also record any on-screen text, excluding the menu.



Video playback and photo review



To browse your Compact Flash card or USB flash drive, press the video  key on the keypad.



The card browser will open; use the  and  arrows to navigate to the file you wish to view and then press OK or video .

Video Playback or Photo review will begin immediately.

You can pause or stop video playback at anytime using the  or  keypad keys.

You can stop reviewing a photo by pressing the  key or pressing .

To Fast-Forward press the  arrow key during playback. To resume normal playback speed, press the video  key.

To Rewind press the  arrow key during playback. To resume normal playback speed, press video .

During playback, you can adjust the sound volume at anytime by pressing F1 or F2.

Storing your Jobs onto your PC

If you have used a USB flash drive connect this to a spare USB port of your PC and go to step 4.

Or:

If you have used a CF card:

- 1 Switch the controller off.
- 2 Connect the USB cable to the unit and to your computer.
- 3 Your computer will recognize the unit as a Mass Storage Device.
- 4 Start flexisight manager.
- 5 Press the Import Button.
- 6 Select the Removable Disk in which your Jobs are stored.
- 7 Press OK.

For more information, please refer to the Operation Manual available in the FlexiSight Manager CD or to download from the Radiodetection website.



SAFETY WARNINGS

The system is not earthed. If mains operated equipment is connected to the system then the external equipment must be earthed in accordance with the manufacturer's instructions. Failure to comply with this may cause the unit to become live and be a lethal hazard.

DO NOT USE the GatorCam4 system in potentially explosive environments. This equipment is **NOT** approved for use in hazardous Locations.

Pushrod reels are heavy. Use the wheels (Midi and Specialist models) to assist transport. Observe heavy-lifting safety practices when lifting the reel.

Foul water systems can be a source of biological hazards. Wear appropriate protection when handling the GatorCam4usb controller and the pushrod reel and camera.

The camera will get hot during use. This is normal. Exercise care when handling the camera at all times.

Maintenance

Clean and sanitize the GatorCam4 system at regular intervals and after conducting an inspection.

The GatorCam4 system contains no user serviceable parts; do not dismantle any component of the GatorCam4 system, including the controller, reel and camera.

Radiodetection recommends that only authorized service centers carry out service of this product. Service elsewhere will invalidate the manufacturer's warranty.

For information regarding any service needs, please visit:

www.radiodetection.com or contact your local Radiodetection representative or dealer.

Training

Radiodetection provides training services for most Radiodetection products. Our qualified instructors will train equipment operators or other personnel at your preferred location or at Radiodetection headquarters.

For more information go to **www.radiodetection.com** or contact your local Radiodetection representative.

Radiodetection Ltd.

Western Drive, Bristol BS14 0AF, UK

Tel: +44 (0) 117 976 7776 Fax: +44 (0) 117 976 7775

Email: rd.sales.uk@spx.com

Radiodetection

154 Portland Road, Bridgton, ME 04009, USA

Tel: +1 (207) 647 9495 Toll Free: +1 (877) 247 3797

Fax: +1 (207) 647 9496 Email: rd.sales.us@spx.com

www.radiodetection.com

Copyright 2011 Radiodetection Ltd - SPX Corporation.
All rights reserved. Radiodetection is a subsidiary of SPX Corporation. SPX and Radiodetection are trademarks of Radiodetection Ltd. and SPX Corporation. Due to a policy of continued development, we reserve the right to alter or amend any published specification without notice. This document may not be copied, reproduced, transmitted, modified or used, in whole or in part, without the prior written consent of Radiodetection Ltd.



Radiodetection®
AN SPX COMPANY